

A4-LIA
4 inch New Construction IC Airtight LED Housing

Catalog #		Prepared by	LiteHarbor
Project		Date	
Notes			

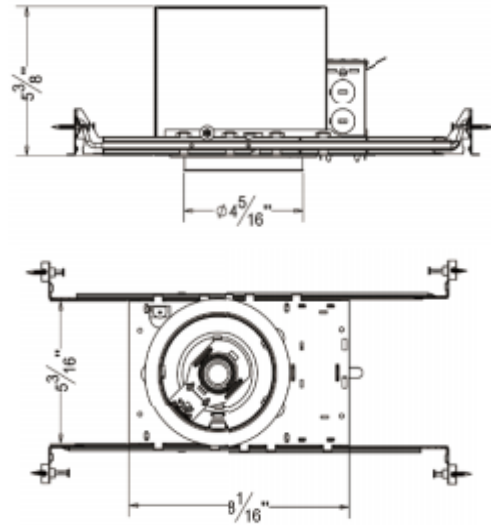

RECESSED DOWNLIGHT

4 inch New Construction IC Airtight LED Housing

Housing

- 1) Die-formed aluminum for maximum heat dissipation and rust protection
- 2) Designed for New Construction installation
- 3) Housing can be installed in 1/2" to 1-3/8" thick ceilings.

Hanger Bar

- 1) Allow housing to be positioned and locked at any point within a 24" joist span.
- 2) Can be shortened for 12" joists
- 3) Can be positioned on long or short axis of the housing
- 4) Contain integral nail
- 5) Hanger fit onto T-bar spline for quick alignment

Junction Box

- 1) ETL listed for through branch wiring
- 2) 2 in-2 out or 4 in-4 out J-box for your better choices
- 3) Designed for straight through conduit runs
- 4) 1/2" and 3/4" romex wiring knockouts

Connection

- 1) Polarity-specific EZ-connect system engineered to match with Liteharbor LED Retrofit Downlights.
- 2) Meets strict code requirement where Edison Base Sockets have been banned.

Listing

ETL listed for damp location W/Feed through

For Specific Order Matrix please take our LED Retro Downlight Cut Sheet for References.

Other Special requirement please confirm with factory



Liteharbor Lighting Technology Co., Ltd.
 New Industry Area Hecun Danzao Town
 Nanhai Foshan City Guangdong China

TEL: +86-757-8180 8675
 FAX: +86-757-8180 8685
 E-mail: info@liteharbor.com

Website: www.liteharbor.com
 Specifications subject to change w/o notice
 Revision: Jan. 2015