

# EML213-6C

## Remote Emergency Light

Catalog #		Prepared by	LiteHarbor
Project		Date	
Notes			



### Description

The product is our company's own design of intelligent mainly used in fire emergency and evacuation instructions, in line with UL standards, with emergency conversion function, 12 hours timer charging, simulated blackout, 30 days, 360 days of self diagnostic testing standard, signal filling simulation test, fault indication, fault alarm, battery open circuit, short circuit detection, load light source open circuit, short circuit detection, instantaneous delay time delay charging and other functions. microcomputer intelligent control, simple operation, only one function key.

### Features

- Emergency conversion function
- 12 hours timing charging
- Simulated blackout.
- Fault indication function
- Fault alarm function
- Self diagnostic testing standard
- Battery Over-discharge Protection function
- Instantaneous trip, time delay timing
- can add  $2 \leq N \leq 6$  lamps.

### ORDER MATRIX | Example: EML213-6C

	<u>A</u>	<u>B</u>	<u>C</u>	<u>D</u>	<u>E</u>
	Series				
EML213-6C	LED Emergency Light				
	Input Voltage				
U	120-347VAC				
	Wattage				
15	LED 15W				
	Battery				
AC	AC Only Battery Backup				
	Housing Colour				
WH	White				
BK	Black				
GY	Gray				



EXIT & EMERGENCY LIGHT



**Liteharbor Lighting Technology Co., Ltd.**

New Industry Area Hecun Danzao Town  
Nanhai Foshan City Guangdong China

TEL: +86-757-8180 8687

FAX: +86-757-8180 8685

E-mail: info@liteharbor.com

Website: www.liteharbor.com

Specifications subject to change w/o notice

Revision: Mar. 2017

## Technical Data

Body Material: Iron Plate/Aluminum  
Hazardous Rating: CLASS 1 Division 2  
Hazardous Rating Group: A B C D  
Finish: White/Black/Gray  
Light Source Lamps: LED  
Operation Temperature(°F): -40~248  
Operation Temperature (°C): -40~120  
Mounting: Back Mount  
Wet Location Rated: YES  
Indoor: YES

## Battery Parameters

Battery Type: Lead-acid Battery  
Power: 15W max  
Voltage: 120-347 VAC  
Frequency: 50/60Hz  
Power Factor: >0.98  
Emergency Time  $1 \leq N \leq 6 : \geq 90\text{min}$ (Battery capacity=2.6Ah)  
 $7 \leq N \leq 12 : \geq 90\text{min}$ (Battery capacity=4.5Ah)  
 $12 \leq N \leq 24 : \geq 90\text{min}$ (Battery capacity=9Ah)

## Warranty

5-Year Limited Warranty

## Single Lamp Parameters

Power: 2W max  
Input Voltage: 12V  
Color Temperature: 5000K  
CRI: >80  
Luminous Flux: 180lm  
Light Source: SMD

## Voltage Drop

Power (W)	Voltage (V)	Wire Size (AWG)	Line Length (M)	Voltage Drop (V)
2W Max	12VDC Max	18	$\leq 200$	$\leq 10\%$
		16	$\leq 320$	
		14	$\leq 500$	
		12	$\leq 800$	
		10	$\leq 1200$	

## Packing



Inner Box: 260X94X225MM 1PSC/CTN Outer Carton: 59.5X27.5X25CM 6PSC/CTN



Inner Box: 170X130X125MM 1PSC/CTN Outer Carton: 41X35.5X27.5CM 12pcs/CTN



Inner Box: 145X132X110MM 1PSC/CTN Outer Carton: 55X45.5X24.5CM 24PSC/CTN



Inner Box: 132X132X125MM 1PSC/CTN Outer Carton: 55X41.5X27.5CM 24PSC/CTN



**Liteharbor Lighting Technology Co., Ltd.**

New Industry Area Hecun Danzao Town  
Nanhai Foshan City Guangdong China

TEL: +86-757-8180 8687

FAX: +86-757-8180 8685

E-mail: info@liteharbor.com

Website: www.liteharbor.com

Specifications subject to change w/o notice

Revision: Mar. 2017

## Dimensions

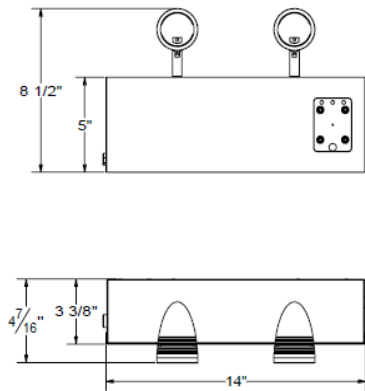

## Wiring Diagram

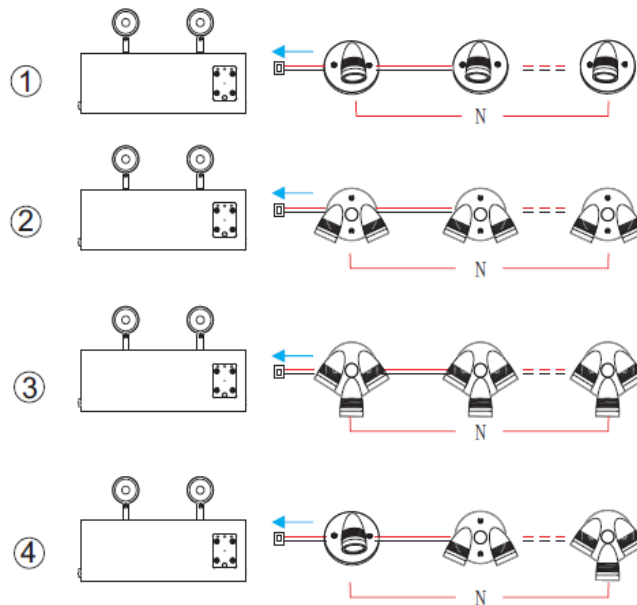
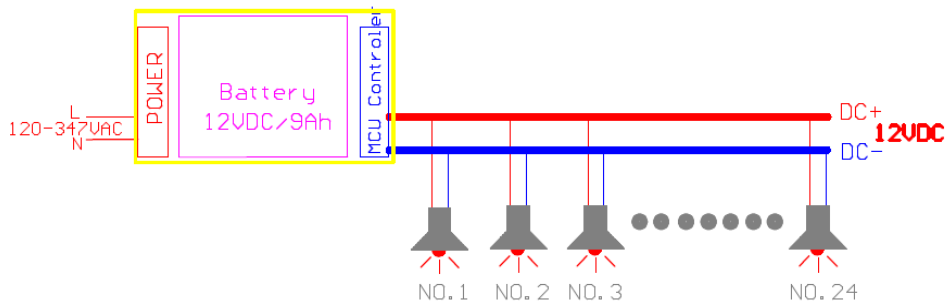

N is the number of lamp(not the lamp modules number, is the bullet head number, including the bullet head on the battery box)



**Liteharbor Lighting Technology Co., Ltd.**

New Industry Area Hecun Danzao Town  
Nanhai Foshan City Guangdong China

TEL: +86-757-8180 8687

FAX: +86-757-8180 8685

E-mail: info@liteharbor.com

Website: www.liteharbor.com

Specifications subject to change w/o notice

Revision: Mar. 2017