

LED CABINET LIGHT WITH 6 PCS LAMP BEADS

Catalog #		Prepared by	LiteHarbor
Project		Date	
Notes			



LED CABINET LIGHT

Descriptions

Liteharbor Cabinet Light is the perfect solution for the kitchen lighting, these fixtures are important for work space lighting or as aesthetic complements or both.

Features

- Die-casting aluminum light bar, stainless steel mounting bracket and screws.
- Break off corners on mounting plate for easy install.
- Operates at 12V with no loss in output due to constant current technology.
- Removable light bar can suitable for different application.
- 120 degree beam angle with 6 pcs LED chips at a total of 1.5W.
- Using LED SMD 3535/5050 Chips, the quality is guaranteed.

Applications

Suitable for cabinet, counter, cupboard, shelf, display, pelmet, etc.



Liteharbor Lighting Technology Co., Ltd.

New Industry Area Hecun Danzao Town
Nanhai Foshan City Guangdong China

TEL: +86-757-8180 8675

FAX: +86-757-8180 8685

E-mail: info@liteharbor.com

Website: www.liteharbor.com

Specifications subject to change w/o notice

Revision: Jan. 2019

Product Details

Product Series	LED Cabinet Light
Item No.	DG5013

Electronic Performance

Input Voltage	AC/DC12V
Frequency Range	60Hz
System Power	1.5W
PF	>0.9
Driver	Liteharbor
Dimmable	Non-dimmable

Optical Performance

Total Lumen	100 lm
LED Light Source	SMD3535/5050
LED Qty	6 PCS
CCT	2700K-5000K
CRI	90+
IP Rating	IP66
Beam Angle	120 Degree

Mechanical Performance

Material	Stainless steel/Aluminium/Bronzed
IP Rating	IP65
Finish	White/Black/Brown
Dimensions	327.5mm*25mm*18.5mm

Warranty

5 Years Limited Warranty.



Liteharbor Lighting Technology Co., Ltd.

New Industry Area Hecun Danzao Town
Nanhai Foshan City Guangdong China

TEL: +86-757-8180 8675

FAX: +86-757-8180 8685

E-mail: info@liteharbor.com

Website: www.liteharbor.com

Specifications subject to change w/o notice

Revision: Jan. 2019



Dimensions

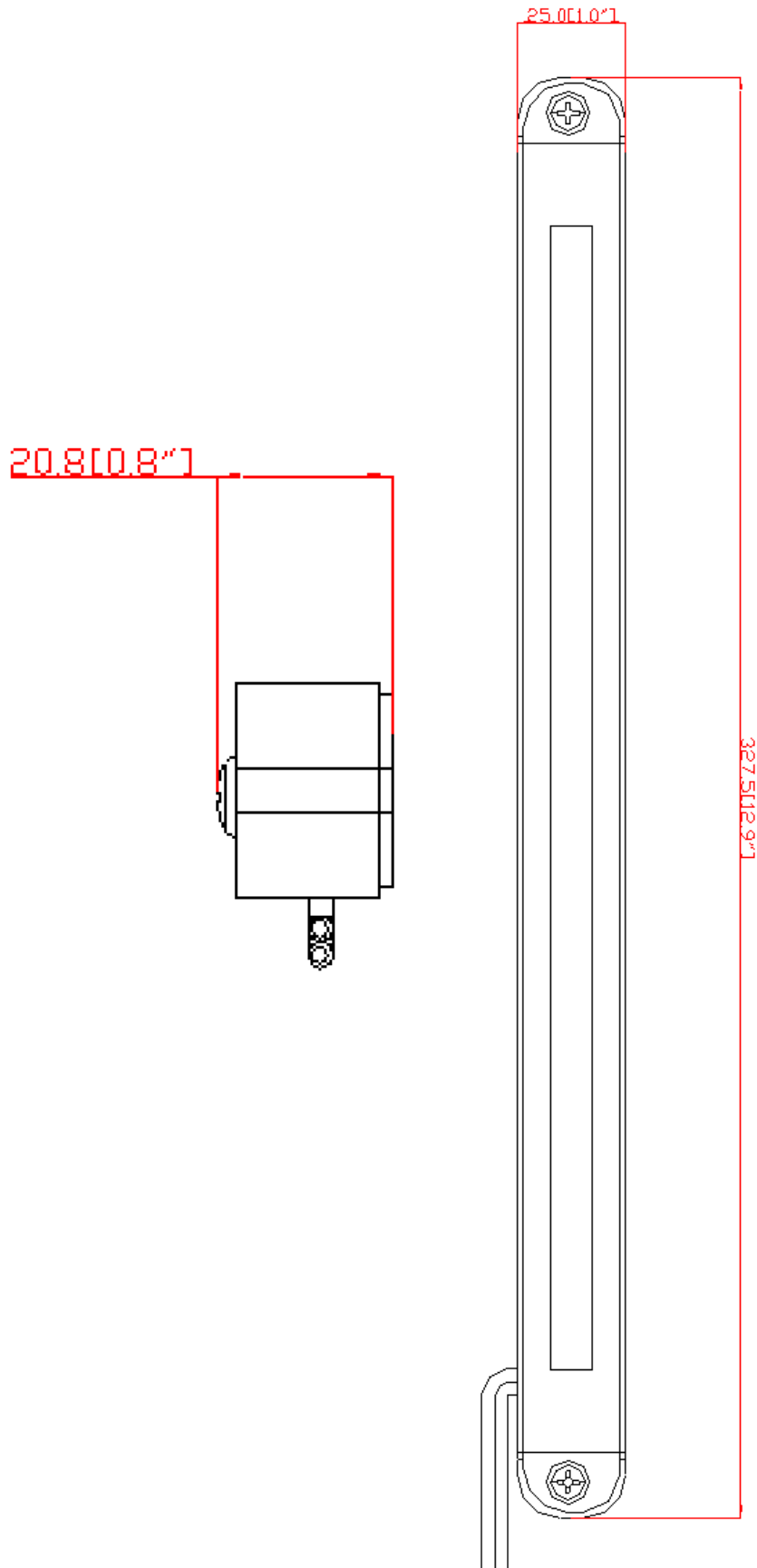

LED CABINET LIGHT



Liteharbor Lighting Technology Co., Ltd.

New Industry Area Hecun Danzao Town
Nanhai Foshan City Guangdong China

TEL: +86-757-8180 8675

FAX: +86-757-8180 8685

E-mail: info@liteharbor.com

Website: www.liteharbor.com

Specifications subject to change w/o notice

Revision: Jan. 2019